

CDCLD200
CDCLD400
CDCLD500

**SURFACE MOUNT SILICON
CURRENT LIMITING DIODES**



www.centrasemi.com

DESCRIPTION:

The CENTRAL SEMICONDUCTOR CDCLD200, CDCLD400, and CDCLD500 are Current Limiting Diodes (CLDs) specifically designed for applications requiring a constant current over a wide voltage range. The series is designed with a unique process that holds regulator current constant over temperature excursions (zero temperature coefficient). The devices are available in the thermally efficient DPAK package outline.

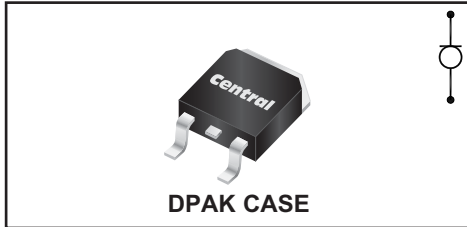

MARKING: FULL PART NUMBER

FEATURES:

- Zero temperature coefficient
- High regulator currents available
- Industry standard thermally efficient DPAK

MAXIMUM RATINGS: ($T_A=25^\circ\text{C}$ unless otherwise noted)

	SYMBOL	CDCLD200	CDCLD400	CDCLD500	UNITS
Peak Operating Voltage	P_{OV}	27	13.5	10.8	V
Peak Operating Voltage ($T_C=35^\circ\text{C}$)	P_{OV}		50		V
Power Dissipation (Note 1)	P_D		6.25		W
Power Dissipation ($T_C=35^\circ\text{C}$) (Note 1)	P_D		28.75		W
Thermal Resistance	θ_{JC}		4.0		$^\circ\text{C/W}$
Operating and Storage Junction Temperature	T_J, T_{stg}		-55 to +150		$^\circ\text{C}$

Note 1: Mounted on 900mm² 4-layer PCB with 2-ounce copper traces.

ELECTRICAL CHARACTERISTICS: ($T_A=25^\circ\text{C}$)

Type	Regulator Current ($t_p=4.5\text{ms}$)			Maximum Limiting Voltage ($t_p=5.0\text{ms}$)
	$I_p @ V_T=5.0\text{V}$			$V_L @ 0.8 \times I_p \text{ MIN}$
	MIN mA	NOM mA	MAX mA	V
CDCLD200	170	200	230	2.0
CDCLD400	340	400	460	2.0
CDCLD500	425	500	575	2.0

CDCLD200
 CDCLD400
 CDCLD500



**SURFACE MOUNT SILICON
 CURRENT LIMITING DIODES**

DPAK CASE - MECHANICAL OUTLINE

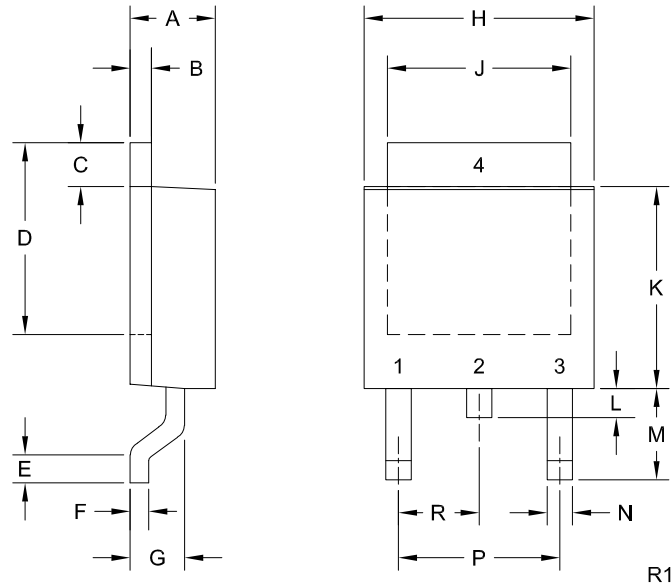

LEAD CODE:

- 1) Cathode
 - 2) Anode
 - 3) No Connection
 - 4) Anode
- Pin 2 is common to the tab (4)

MARKING: FULL PART NUMBER

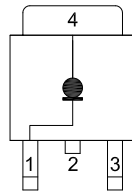

SYMBOL	DIMENSIONS			
	INCHES		MILLIMETERS	
	MIN	MAX	MIN	MAX
A	0.083	0.108	2.10	2.75
B	0.016	0.032	0.40	0.81
C	0.035	0.063	0.89	1.60
D	0.203	0.228	5.15	5.79
E	0.020	-	0.51	-
F	0.016	0.024	0.40	0.60
G	0.051	0.071	1.30	1.80
H	0.248	0.268	6.30	6.81
J	0.197	0.217	5.00	5.50
K	0.209	0.245	5.30	6.22
L	0.025	0.040	0.64	1.02
M	0.090	0.115	2.30	2.91
N	0.012	0.045	0.30	1.14
P	0.180		4.60	
R	0.090		2.30	

DPAK (REV: R1)

R4 (1-April 2021)

CDCLD200
CDCLD400
CDCLD500



SURFACE MOUNT SILICON
CURRENT LIMITING DIODES

TYPICAL ELECTRICAL CHARACTERISTICS

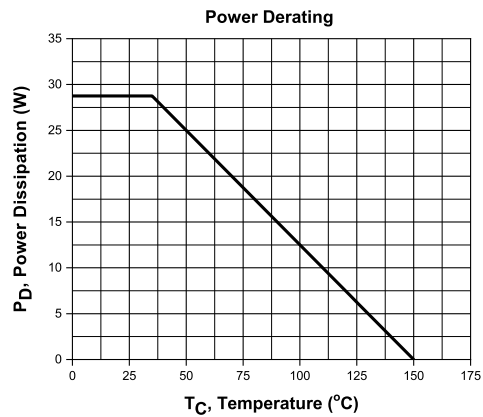
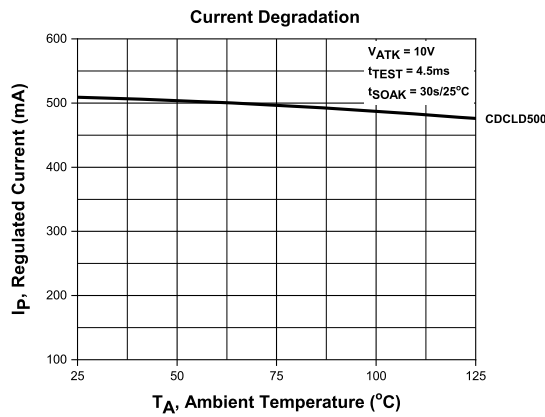
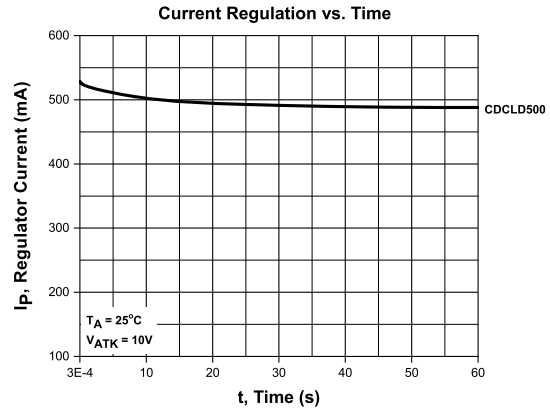
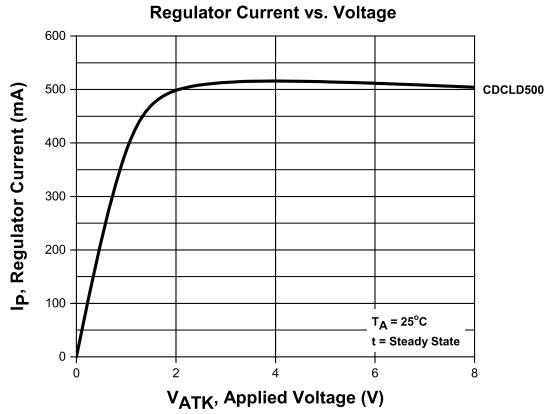

R4 (1-April 2021)

CDCLD200
CDCLD400
CDCLD500

SURFACE MOUNT SILICON
CURRENT LIMITING DIODES



TYPICAL APPLICATIONS

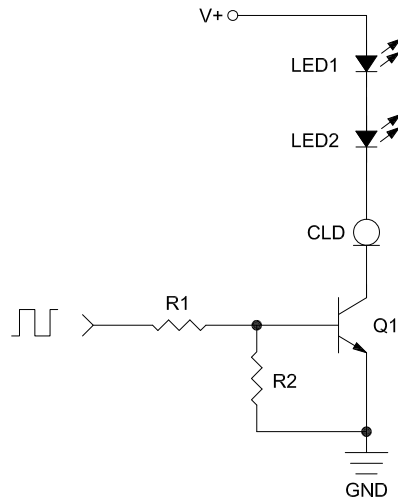

Figure 1. CLDs can be used to limit the current flowing through LED strings. Their dynamic performance make them an excellent replacement for current limiting resistors, as they allow for continuous current regulation regardless of input voltage. LED strings like this are commonly used in dimming lighting systems. By using a PWM input to control the transistor, the LED luminosity can be controlled by extending or decreasing the pulse width, allowing for control over the brightness of the LED.

R4 (1-April 2021)

CDCLD200
CDCLD400
CDCLD500

SURFACE MOUNT SILICON
CURRENT LIMITING DIODES



TYPICAL APPLICATIONS

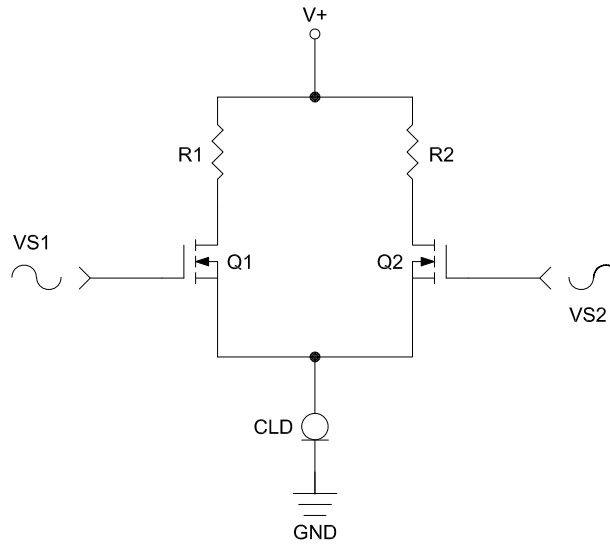

Figure 2. When designing differential amplifiers, it is essential to use a high impedance tail resistor to control both differential and common mode function. For differential signals, the tail resistor effectively splits the current amongst the transistors. This ensures proportional current increase and decrease between the transistors. The high impedance drives down the common mode gain and increases the common mode rejection ratio, thus yielding a more ideal amplifier. Ideally, an infinite impedance current source would be used in place of the tail resistor. While the ideal current source doesn't exist, CLDs serve as an excellent replacement for the tail resistor and also perform much like an active current source, both regulating the circuit to a constant current and presenting a large tail impedance. This yields a larger CMRR than using a high impedance tail resistor would.

R4 (1-April 2021)

OUTSTANDING SUPPORT AND SUPERIOR SERVICES



PRODUCT SUPPORT

Central's operations team provides the highest level of support to insure product is delivered on-time.

- Supply management (Customer portals)
- Inventory bonding
- Consolidated shipping options
- Custom bar coding for shipments
- Custom product packing

DESIGNER SUPPORT/SERVICES

Central's applications engineering team is ready to discuss your design challenges. Just ask.

- Free quick ship samples (2nd day air)
- Online technical data and parametric search
- SPICE models
- Custom electrical curves
- Environmental regulation compliance
- Customer specific screening
- Up-screening capabilities
- Special wafer diffusions
- PbSn plating options
- Package details
- Application notes
- Application and design sample kits
- Custom product and package development

REQUESTING PRODUCT PLATING

1. If requesting Tin/Lead plated devices, add the suffix " TIN/LEAD" to the part number when ordering (example: 2N2222A TIN/LEAD).
2. If requesting Lead (Pb) Free plated devices, add the suffix " PBFREE" to the part number when ordering (example: 2N2222A PBFREE).

CONTACT US

Corporate Headquarters & Customer Support Team

Central Semiconductor Corp.
145 Adams Avenue
Hauppauge, NY 11788 USA
Main Tel: (631) 435-1110
Main Fax: (631) 435-1824
Support Team Fax: (631) 435-3388
www.centrasemi.com

Worldwide Field Representatives:
www.centrasemi.com/wwreps

Worldwide Distributors:
www.centrasemi.com/wwdistributors

For the latest version of Central Semiconductor's **LIMITATIONS AND DAMAGES DISCLAIMER**, which is part of Central's Standard Terms and Conditions of sale, visit: www.centrasemi.com/terms